

# SOM-IMX8MP

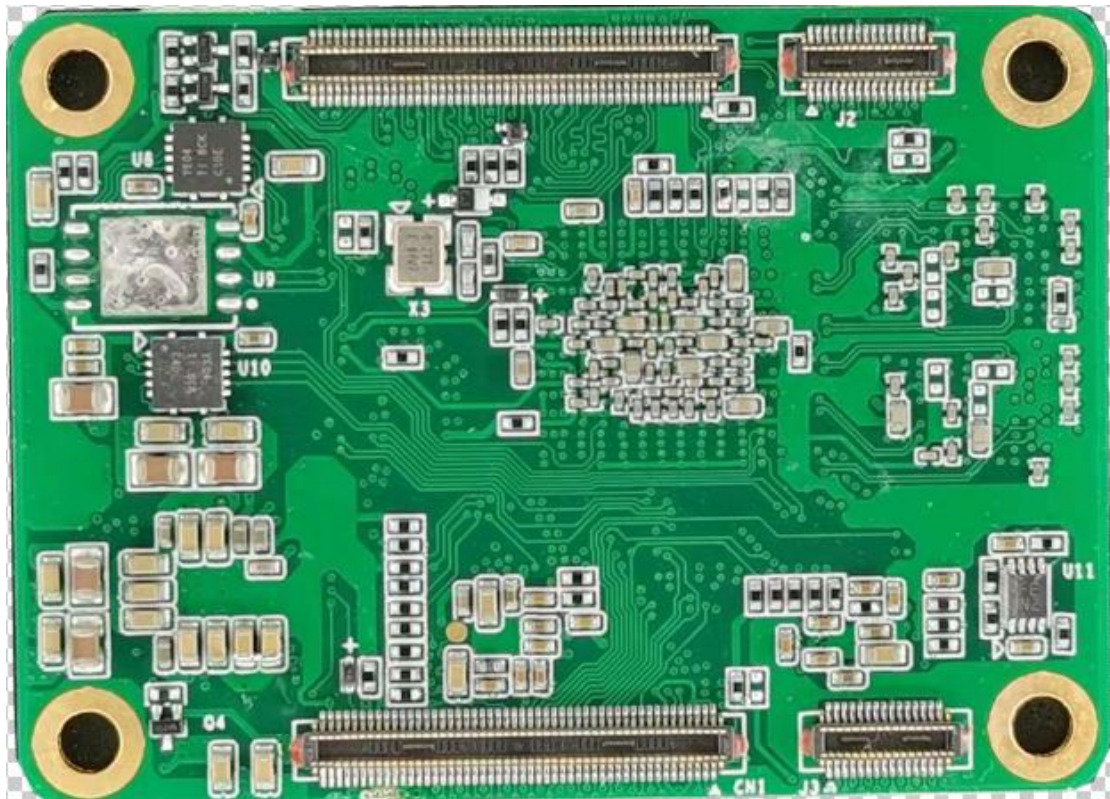

[www.emtop-tech.com](http://www.emtop-tech.com)  
[sales@emtop-tech.com](mailto:sales@emtop-tech.com)

<https://github.com/EMTOP-TECH/SOM-IMX8MP>  
[support@emtop-tech.com](mailto:support@emtop-tech.com)

## Revision History

Date	Version	Description
2023-05-20	V1.0	First Released
2023-06-27	V1.1	Update Git hub Link
2023-07-01	V1.2	Check And Correction

# Chapter 1. Introduction

## 1.1. Introduction

The SOM-IMX8MP is a System on Module (SoM) containing processor, memory, eMMC Flash, WIFI module, Ethernet PHY and supporting power circuitry. The SoM is based on NXP i.MX8M Plus series processors, and can be easily used by a designer in their own products and systems, help customers to bring their products into market quickly.

The electrical interface of SoM is via two 100-pin high density BTB connectors and two 30-pin high density BTB connectors, and the signal definition of two 100-pin connectors is compatible with CM4 of Raspberry, so it could be an high performance alternative of CM4 for some products embedded in CM4.

## 1.2. Features

Key features of the SoM are as follows:

- NXP Quad core Cortex-A53 (ARM v8) 64-bit SoC @ 1.8GHz
- 2.3 TOP/s Neural Network performance available for user applications
- ARM Cortex-M7 Core CPU operating up to 800 MHz
- 375 Mpixel/s HDR Image Sensor Processor ISP
- Hifi4 Audio DSP, operating up to 800 MHz
- Small Footprint 55mm × 40mm × 4.7mm module
  - 4 × M2.5 mounting holes
- H.265 (up to 1080p60 encode and decode), H.264 (up to 1080p60 encode and decode)
- OpenGL ES 3.0 graphics, OpenCL 1.2
- Options for 2GB, 4GB or 8GB LPDDR4-4000 SDRAM
- Options for 8GB, 16GB, 32GB or 64GB eMMC Flash memory
  - Peak eMMC bandwidth 200MBytes/s
- 64Mb SPI Nor Flash
- Option for certified radio module with:
  - 2.4 GHz, 5.0 GHz IEEE 802.11 b/g/n/ac wireless
  - Bluetooth 5.1, BLE
- 2 x Gigabit Ethernet controller
  - One Gigabit Ethernet controller with PHY on-board supporting IEEE 1588
  - One Gigabit Ethernet controller supporting IEEE 1588, PHY is needed on baseboard
- 1 × PCIe 1-lane Host, Gen 3 ( 5Gbps )
- 2 × USB 3.0 port ( highspeed )

<a href="http://www.emtop-tech.com">www.emtop-tech.com</a>	<a href="https://github.com/EMTOP-TECH/SOM-IMX8MP">https://github.com/EMTOP-TECH/SOM-IMX8MP</a>
<a href="mailto:sales@emtop-tech.com">sales@emtop-tech.com</a>	<a href="mailto:support@emtop-tech.com">support@emtop-tech.com</a>

- 66 × GPIO supporting:
  - Up to 3 × UART
  - Up to 4 × I2C
  - Up to 2 × SPI
  - 1 × SDIO interface
  - 2 × CAN
  - 1 × PCM
  - Up to 4 × PWM channels
- 1 × HDMI 2.0a ports (up to 1920 x 1080p60 supported)
- 1 × 4-lane MIPI DSI
- 1 × 4-lane LVDS (up to approximately 1366x768p60)
- 2 × 4-lane MIPI CSI-2
- SPDIF input and output
- Five external synchronous audio interface (SAI) modules
- 8-channel PDM microphone input
- SPDIF input and output
- 1 × SDIO, eMMC 5.1
- Single +5V Power supply input.

### 1.3. Application

- Machine Vision and Robot Controllers
- Building Safety
- Industrial automation
- Weighing Scales
- Smart Toll Systems
- Educational Consoles
- Factory Automation
- Industrial Computers, Gateways and HMIs
- Machine Vision and Robot Controllers
- Traffic Monitors and Flow Optimization
- Vision Payment Systems
- Medical facilities

<a href="http://www.emtop-tech.com">www.emtop-tech.com</a>	<a href="https://github.com/EMTOP-TECH/SOM-IMX8MP">https://github.com/EMTOP-TECH/SOM-IMX8MP</a>
<a href="mailto:sales@emtop-tech.com">sales@emtop-tech.com</a>	<a href="mailto:support@emtop-tech.com">support@emtop-tech.com</a>

## Chapter 2. Mechanical Dimension

SoM dimension as following, viewed from the Top.

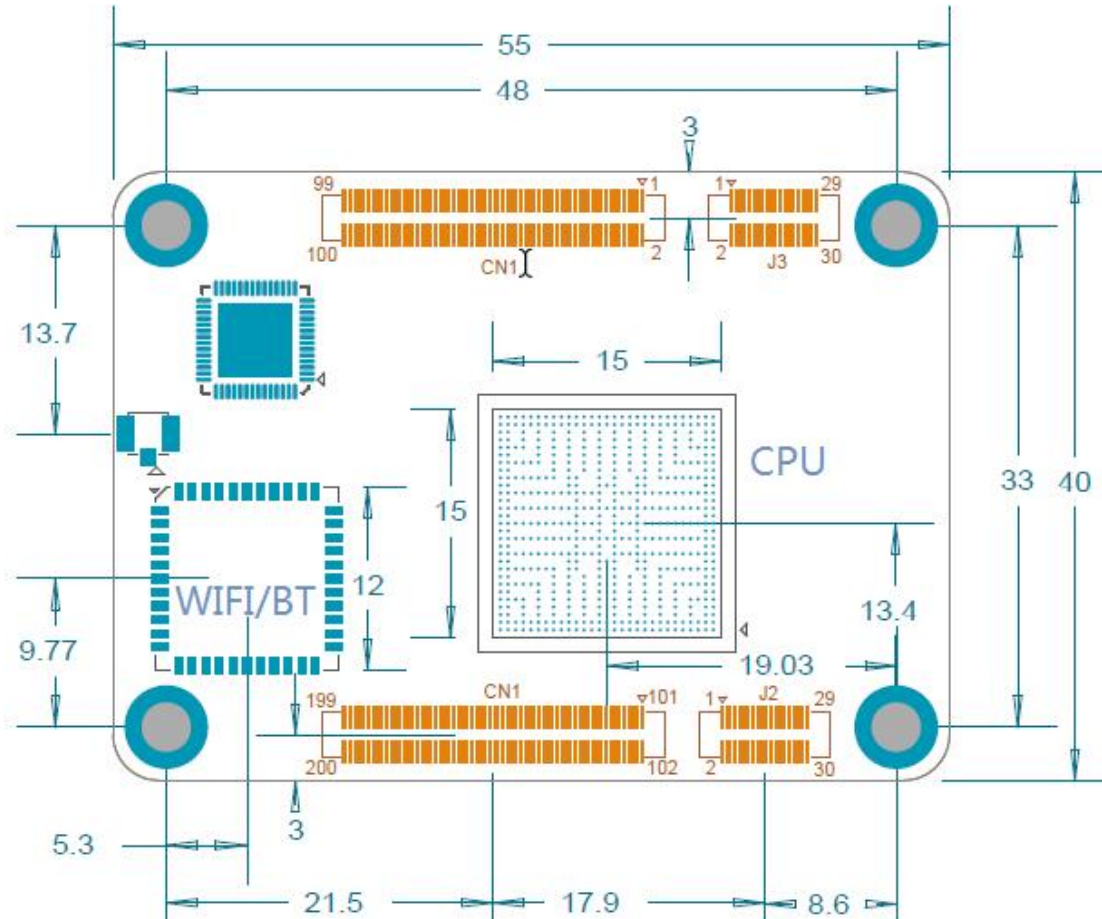

Components in blue are on Top;

Components in Orange are on Bottom;

The height of WIFI/BT module is 1.7mm;

The height of CPU is 1.5mm;

A cooling solution is needed to ensure CPU of SoM to maintain an operational temperature.

The SoM's threaded standoffs can be used to mount a passive or active cooling solution.

<a href="http://www.emtop-tech.com">www.emtop-tech.com</a>	<a href="https://github.com/EMTOP-TECH/SOM-IMX8MP">https://github.com/EMTOP-TECH/SOM-IMX8MP</a>
<a href="mailto:sales@emtop-tech.com">sales@emtop-tech.com</a>	<a href="mailto:support@emtop-tech.com">support@emtop-tech.com</a>

## Chapter 3. Pin Out

CN1				
Number	Signal	Power Domain	Ball Type	Circuit on SoM
1	GND			
2	GND			
3	Ethernet_Pair3_P	Analog	Ethernet PHY	
4	Ethernet_Pair1_P	Analog	Ethernet PHY	
5	Ethernet_Pair3_N	Analog	Ethernet PHY	
6	Ethernet_Pair1_N	Analog	Ethernet PHY	
7	GND			
8	GND			
9	Ethernet_Pair2_N	Analog	Ethernet PHY	
10	Ethernet_Pair0_N	Analog	Ethernet PHY	
11	Ethernet_Pair2_P	Analog	Ethernet PHY	
12	Ethernet_Pair0_P	Analog	Ethernet PHY	
13	GND			
14	GND			
15	Ethernet_nLED3	3.3V	EthernetPHY	LED_ACT
16	Ethernet_SYNC_I N	3.3V	GPIO	
17	Ethernet_nLED2	3.3V	Ethernet PHY	LED_1000
18	Ethernet_SYNC_ OUT	3.3V	GPIO	
19	Ethernet_nLED1	3.3V	Ethernet PHY	LED_10_100
20	GPIO3_IO25	GPIO_V REF	GPIO	
21	SYS_nLED	3.3V	GPIO	System Status LED
22	GND			
23	GND			
24	GPIO4_IO29	3.3V	GPIO	
25	GPIO5_IO01	3.3V	GPIO	
26	GPIO4_IO31	3.3V	GPIO	
27	GPIO4_IO30	3.3V	GPIO	
28	GPIO5_IO05	3.3V	GPIO	
29	GPIO4_IO28	3.3V	GPIO	
30	GPIO5_IO07	3.3V	GPIO	
<a href="http://www.emtop-tech.com">www.emtop-tech.com</a> <a href="mailto:sales@emtop-tech.com">sales@emtop-tech.com</a>			<a href="https://github.com/EMTOP-TECH/SOM-IMX8MP">https://github.com/EMTOP-TECH/SOM-IMX8MP</a> <a href="mailto:support@emtop-tech.com">support@emtop-tech.com</a>	

CN1				
Number	Signal	Power Domain	Ball Type	Circuit on SoM
31	GPIO5_IO02	3.3V	GPIO	
32	GND			
33	GND			
34	GPIO5_IO08	3.3V	GPIO	
35	I2C5_SCL	3.3V	GPIO	1.8K Pull-up to 3.3V
36	I2C5_SDA	3.3V	GPIO	1.8K Pull-up to 3.3V
37	GPIO5_IO06	3.3V	GPIO	
38	GPIO5_IO10	3.3V	GPIO	
39	GPIO5_IO13	3.3V	GPIO	
40	GPIO5_IO12	3.3V	GPIO	
41	GPIO4_IO22	3.3V	GPIO	
42	GND			
43	GND			
44	GPIO5_IO11	3.3V	GPIO	
45	UART4_TXD	3.3V	GPIO	
46	GPIO1_IO07	3.3V	GPIO	
47	UART4_RXD	3.3V	GPIO	
48	GPIO4_IO27	3.3V	GPIO	
49	GPIO5_IO00	3.3V	GPIO	
50	GPIO2_IO20	VDD_S D2	GPIO	
51	UART2_RXD	3.3V	GPIO	
52	GND			
53	GND			
54	GPIO5_IO09	3.3V	GPIO	
55	UART2_TXD	3.3V	GPIO	
56	I2C2_SCL	3.3V	GPIO	1.8K Pull-up to 3.3V
57	SD2_CLK	VDD_S D2	GPIO	4.7K Pull-up to VDD_SD2
58	I2C2_SDA	3.3V	GPIO	1.8K Pull-up to 3.3V
59	GND			
60	GND			
61	SD2_DAT3	VDD_S D2	GPIO	
62	SD2_CMD	VDD_S D2	GPIO	
63	SD2_DAT0	VDD_S D2	GPIO	

CN1				
Number	Signal	Power Domain	Ball Type	Circuit on SoM
64	GPIO3_IO21	GPIO_V REF	GPIO	
65	GND			
66	GND			
67	SD2_DAT1	VDD_S D2	GPIO	
68	GPIO3_IO22	GPIO_V REF	GPIO	
69	SD2_DAT2	VDD_S D2	GPIO	
70	GPIO3_IO23	GPIO_V REF	GPIO	
71	GND			
72	GPIO3_IO24	GPIO_V REF	GPIO	
73	Reserved			
74	GND			
75	VSD_3V3	3.3V	Power Output	
76	SD2_nCD	VDD_S D2	GPIO	4.7K Pull-up to VDD_SD2
77	+5V (Input)	5V	Power Input	
78	GPIO_VREF	3.3V/1.8 V	Power Input	
79	+5V (Input)	5V	Power Input	
80	I2C3_SCL	3.3V	GPIO	1.8K Pull-up to 3.3V
81	+5V (Input)	5V	Power Input	
82	I2C3_SDA	3.3V	GPIO	1.8K Pull-up to 3.3V
83	+5V (Input)	5V	Power Input	
84	3.3V_OUT (Output)	3.3V	Power Output	
85	+5V (Input)	5V	Power Input	
86	3.3V_OUT (Output)	3.3V	Power Output	
87	+5V (Input)	5V	Power Input	
88	1.8V_OUT (Output)	1.8V	Power Output	
89	GPIO3_IO20	GPIO_V REF	GPIO	

<a href="http://www.emtop-tech.com">www.emtop-tech.com</a>	<a href="https://github.com/EMTOP-TECH/SOM-IMX8MP">https://github.com/EMTOP-TECH/SOM-IMX8MP</a>
<a href="mailto:sales@emtop-tech.com">sales@emtop-tech.com</a>	<a href="mailto:support@emtop-tech.com">support@emtop-tech.com</a>



CN1				
Number	Signal	Power Domain	Ball Type	Circuit on SoM
90	1.8V_OUT (Output)	1.8V	Power Output	
91	GPIO3_IO19	GPIO_V REF	GPIO	
92	SYS_nRST	3.3V	Input	10K Pull-up to 3.3V
93	BOOT_MODE1	1.8V	Input	1K Pull-up to 1.8V
94	Reserved			
95	Reserved			
96	Reserved			
97	GPIO1_IO06	3.3V	GPIO	
98	GND			
99	ON_OFF	1.8V	Input	100K Pull-up to 1.8V
100	nEXTRST	3.3V	Output	10K Pull-up to 3.3V
101	USB1_OTG_ID	3.3V	USB PHY	
102	PCIe_CLK_nREQ	3.3V	GPIO	
103	USB1_N	3.3V	USB PHY	
104	Reserved			
105	USB1_P	3.3V	USB PHY	
106	Reserved			
107	GND			
108	GND			
109	PCIe_nRST	3.3V	GPIO	
110	PCIe_CLK_P	1.8V	PCIe PHY	
111	Reserved			
112	PCIe_CLK_N	1.8V	PCIe PHY	
113	GND			
114	GND			
115	CAM1_D0_N	1.8V	MIPI CSI PHY	
116	PCIe_RX_P	1.8V	PCIe PHY	
117	CAM1_D0_P	1.8V	MIPI CSI PHY	
118	PCIe_RX_N	1.8V	PCIe PHY	
119	GND			
120	GND			
121	CAM1_D1_N	1.8V	MIPI CSI PHY	
122	PCIe_TX_P	1.8V	PCIe PHY	
123	CAM1_D1_P	1.8V	MIPI CSI PHY	
124	PCIe_TX_N	1.8V	PCIe PHY	
125	GND			

CN1				
Number	Signal	Power Domain	Ball Type	Circuit on SoM
126	GND			
127	CAM1_C_N	1.8V	MIPI CSI PHY	
128	CAM0_D0_N	1.8V	MIPI CSI PHY	
129	CAM1_C_P	1.8V	MIPI CSI PHY	
130	CAM0_D0_P	1.8V	MIPI CSI PHY	
131	GND			
132	GND			
133	CAM1_D2_N	1.8V	MIPI CSI PHY	
134	CAM0_D1_N	1.8V	MIPI CSI PHY	
135	CAM1_D2_P	1.8V	MIPI CSI PHY	
136	CAM0_D1_P	1.8V	MIPI CSI PHY	
137	GND			
138	GND			
139	CAM1_D3_N	1.8V	MIPI CSI PHY	
140	CAM0_C_N	1.8V	MIPI CSI PHY	
141	CAM1_D3_P	1.8V	MIPI CSI PHY	
142	CAM0_C_P	1.8V	MIPI CSI PHY	
143	Reserved			
144	GND			
145	EARC_N_HPD	1.8V	HDMI PHY	Output
146	USB1_TXN	3.3V	USB PHY	
147	EARC_P_UTIL	1.8V	HDMI PHY	Output
148	USB1_TXP	3.3V	USB PHY	
149	EARC_AUX	1.8V	HDMI PHY	Input
150	GND			
151	HDMI_CEC	3.3V	HDMI PHY	
152	USB1_RXN	3.3V	USB PHY	
153	HDMI_HOTPLUG	5V	HDMI PHY	
154	USB1_RXP	3.3V	USB PHY	
155	GND			
156	GND			
157	LVDS0_TX0_N	1.8V	LVDS PHY	
158	LVDS0_CLK_N	1.8V	LVDS PHY	
159	LVDS0_TX0_P	1.8V	LVDS PHY	
160	LVDS0_CLK_P	1.8V	LVDS PHY	
161	GND			
162	GND			
163	LVDS0_TX1_N	1.8V	LVDS PHY	

<a href="http://www.emtop-tech.com">www.emtop-tech.com</a>	<a href="https://github.com/EMTOP-TECH/SOM-IMX8MP">https://github.com/EMTOP-TECH/SOM-IMX8MP</a>
<a href="mailto:sales@emtop-tech.com">sales@emtop-tech.com</a>	<a href="mailto:support@emtop-tech.com">support@emtop-tech.com</a>

CN1				
Number	Signal	Power Domain	Ball Type	Circuit on SoM
164	LVDS0_TX3_N	1.8V	LVDS PHY	
165	LVDS0_TX1_P	1.8V	LVDS PHY	
166	LVDS0_TX3_P	1.8V	LVDS PHY	
167	GND			
168	GND			
169	LVDS0_TX2_N	1.8V	LVDS PHY	
170	HDMI_TX2_P	1.8V	HDMI PHY	
171	LVDS0_TX2_P	1.8V	LVDS PHY	
172	HDMI0_TX2_N	1.8V	HDMI PHY	
173	GND			
174	GND			
175	DSI_D0_N	1.8V	MIPI DSI PHY	
176	HDMI_TX1_P	1.8V	HDMI PHY	
177	DSI_D0_P	1.8V	MIPI DSI PHY	
178	HDMI_TX1_N	1.8V	HDMI PHY	
179	GND			
180	GND			
181	DSI_D1_N	1.8V	MIPI DSI PHY	
182	HDMI_TX0_P	1.8V	HDMI PHY	
183	DSI_D1_P	1.8V	MIPI DSI PHY	
184	HDMI_TX0_N	1.8V	HDMI PHY	
185	GND			
186	GND			
187	DSI_C_N	1.8V	MIPI DSI PHY	
188	HDMI_CLK_P	1.8V	HDMI PHY	
189	DSI_C_P	1.8V	MIPI DSI PHY	
190	HDMI_CLK_N	1.8V	HDMI PHY	
191	GND			
192	GND			
193	DSI_D2_N	1.8V	MIPI DSI PHY	
194	DSI_D3_N	1.8V	MIPI DSI PHY	
195	DSI_D2_P	1.8V	MIPI DSI PHY	
196	DSI_D3_P	1.8V	MIPI DSI PHY	
197	GND			
198	GND			
199	HDMI_SDA	5V	HDMI PHY	
200	HDMI_SCL	5V	HDMI PHY	

<a href="http://www.emtop-tech.com">www.emtop-tech.com</a>	<a href="https://github.com/EMTOP-TECH/SOM-IMX8MP">https://github.com/EMTOP-TECH/SOM-IMX8MP</a>
<a href="mailto:sales@emtop-tech.com">sales@emtop-tech.com</a>	<a href="mailto:support@emtop-tech.com">support@emtop-tech.com</a>

J2				
Number	Signal	Power Domain	Ball Type	Circuit on SoM
1	GPIO1_IO10	3.3V	GPIO	
2	JTAG_MOD	1.8V	JTAG	
3	GPIO1_IO13	3.3V	GPIO	
4	USB2_RXP	USB 3.3V	USB	
5	GND			
6	USB2_RXN	USB 3.3V	USB	
7	GPIO1_IO12	3.3V	GPIO	
8	Reserved	GND		
9	GPIO1_IO15	3.3V	GPIO	
10	USB2_TXP	USB 3.3V	USB	
11	GPIO1_IO14	3.3V	GPIO	
12	USB2_TXN	USB 3.3V	USB	
13	GPIO1_IO05	3.3V	GPIO	
14	GND			
15	GND			
16	USB2_DN	USB 3.3V	USB	
17	JTAG_TDI	1.8V	JTAG	
18	USB2_DP	USB 3.3V	USB	
19	JTAG_TCK	1.8V	JTAG	
20	Reserved	GND		
21	JTAG_TDO	1.8V	JTAG	
22	CAM0_D2_N	MIPI 1.8V	MIPI CSI	
23	JTAG_TMS	1.8V	JTAG	
24	CAM0_D2_P	MIPI 1.8V	MIPI CSI	
25	USB2_OTG_ID	USB 3.3V	USB	
26	Reserved	GND		
27	GPIO1_IO01	3.3V	GPIO	
28	CAM0_D3_N	MIPI 1.8V	MIPI CSI	
29	GND			
30	CAM0_D3_P	MIPI 1.8V	MIPI CSI	

If all signals of J2 are not been used on base board, matching connector can not be mounted on base board.

J3				
Number	Signal	Power Domain	Ball Type	Circuit on SoM
1	GPIO4_IO17	GPIO_V	GPIO	

<a href="http://www.emtop-tech.com">www.emtop-tech.com</a>	<a href="https://github.com/EMTOP-TECH/SOM-IMX8MP">https://github.com/EMTOP-TECH/SOM-IMX8MP</a>
<a href="mailto:sales@emtop-tech.com">sales@emtop-tech.com</a>	<a href="mailto:support@emtop-tech.com">support@emtop-tech.com</a>

J3				
Number	Signal	Power Domain	Ball Type	Circuit on SoM
		REF		
2	GPIO4_IO11	GPIO_V REF	GPIO	
3	GPIO4_IO19	GPIO_V REF	GPIO	
4	GPIO4_IO14	GPIO_V REF	GPIO	
5	GPIO4_IO16	GPIO_V REF	GPIO	
6	GPIO4_IO13	GPIO_V REF	GPIO	
7	GND			
8	GPIO4_IO20	GPIO_V REF	GPIO	
9	GPIO4_IO11	GPIO_V REF	GPIO	
10	GND			
11	GND			
12	GPIO4_IO10	GPIO_V REF	GPIO	
13	GPIO4_IO09	GPIO_V REF	GPIO	
14	GPIO4_IO15	GPIO_V REF	GPIO	
15	GPIO_VREF			
16	GPIO4_IO18	GPIO_V REF	GPIO	
17	GPIO3_IO14	1.8V	GPIO	
18	GND			
19	GPIO2_IO11	1.8V	GPIO	
20	GPIO4_IO08	GPIO_V REF	GPIO	
21	GPIO4_IO03	GPIO_V REF	GPIO	
22	GPIO4_IO00	GPIO_V REF	GPIO	
23	GPIO4_IO07	GPIO_V REF	GPIO	

<a href="http://www.emtop-tech.com">www.emtop-tech.com</a>	<a href="https://github.com/EMTOP-TECH/SOM-IMX8MP">https://github.com/EMTOP-TECH/SOM-IMX8MP</a>
<a href="mailto:sales@emtop-tech.com">sales@emtop-tech.com</a>	<a href="mailto:support@emtop-tech.com">support@emtop-tech.com</a>

J3				
Number	Signal	Power Domain	Ball Type	Circuit on SoM
24	GPIO4_IO04	GPIO_V REF	GPIO	
25	GPIO4_IO06	GPIO_V REF	GPIO	
26	GPIO4_IO05	GPIO_V REF	GPIO	
27	GPIO4_IO02	GPIO_V REF	GPIO	
28	GPIO4_IO01	GPIO_V REF	GPIO	
29	GND			
30	GND			

If all signals of J3 are not been used on base board, matching connector can not be mounted on base board.

# Chapter 4. Connector

## 4.1. BTB connectors on SoM

The BTB connectors mounted on SoM board are DF40C-30DP-0.4V(51) and DF40C-100DP-0.4V(51) supplied by Hirose. The detail of the connectors are:

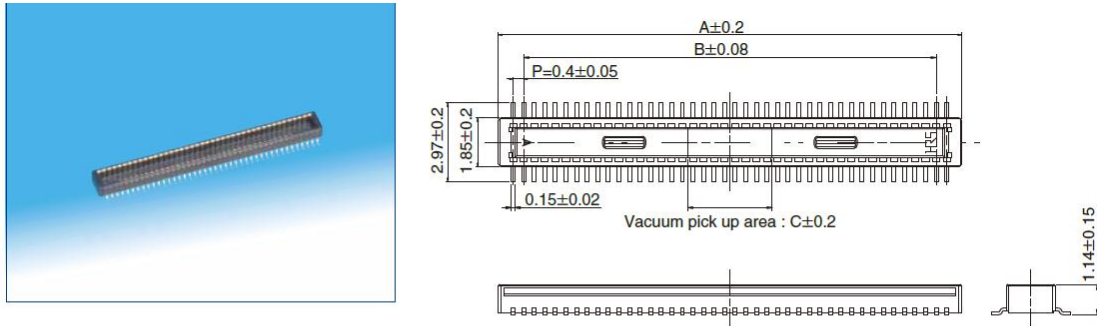

### ◆ Recommended PCB layout

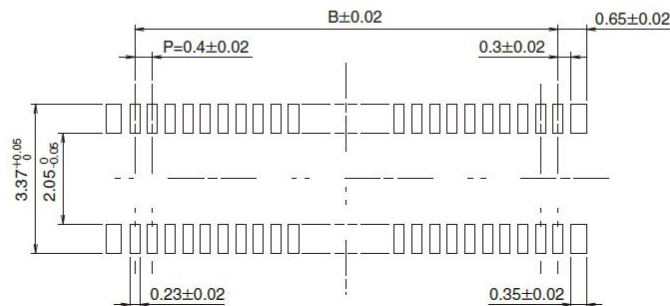

Unit : mm

Part No.	HRS No.	No. of Contacts	A	B	C
DF40C-10DP-0.4V(51)	684-4035-0 51	10	3.52	1.6	1.0
DF40C-12DP-0.4V(51)	684-4149-9 51	12	3.92	2.0	
DF40C-20DP-0.4V(51)	684-4010-9 51	20	5.52	3.6	
DF40C-24DP-0.4V(51)	684-4011-1 51	24	6.32	4.4	1.2
DF40C-30DP-0.4V(51)	684-4012-4 51	30	7.52	5.6	1.5
DF40C-34DP-0.4V(51)	684-4024-3 51	34	8.32	6.4	2.3
DF40C-40DP-0.4V(51)	684-4013-7 51	40	9.52	7.6	3.2
DF40C-44DP-0.4V(51)	684-4077-0 51	44	10.32	8.4	
DF40C-50DP-0.4V(51)	684-4014-0 51	50	11.52	9.6	
DF40C-60DP-0.4V(51)	684-4003-3 51	60	13.52	11.6	
DF40C-70DP-0.4V(51)	684-4015-2 51	70	15.52	13.6	
DF40C-80DP-0.4V(51)	684-4001-8 51	80	17.52	15.6	
DF40C-90DP-0.4V(51)	684-4125-0 51	90	19.52	17.6	
DF40C-100DP-0.4V(51)	684-4032-1 51	100	21.52	19.6	

## 4.2. Suggested BTB connectors on base board

There are two different stacking height BTB connectors that can be mounted on base board:

### 4.2.1. 1.5mm Stacking Height

Stacking Height 1.5mm;

Part Number: DF40HC-30DS-0.4V(51) and DF40HC-100DS-0.4V(51);

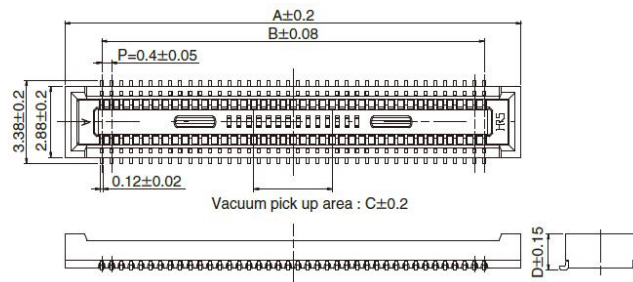
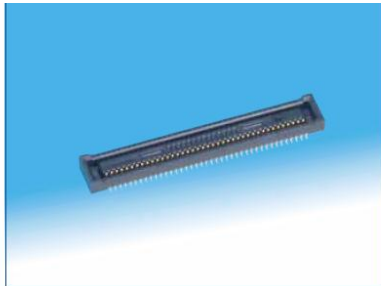

#### ◆ Recommended PCB layout

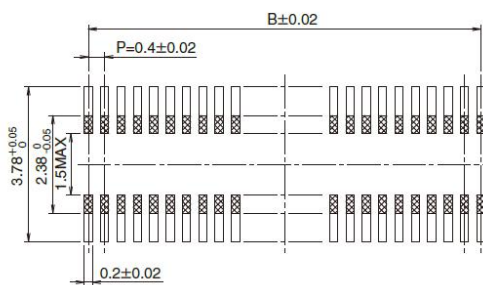

DF40C(Without reinforcing metal fitting)

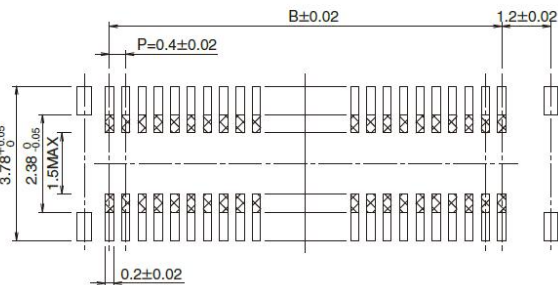

DF40B(With reinforcing metal fitting)

Unit : mm

Part No.	HRS No.	No. of Contacts	A	B	C	D
DF40B-10DS-0.4V(51)	684-4038-8 51	10	4.6	1.6	1.0	1.45
DF40B-12DS-0.4V(51)	684-4152-3 51	12	5.0	2.0		
DF40B-30DS-0.4V(51)	684-4090-8 51	30	8.6	5.6		
DF40B-50DS-0.4V(51)	684-4018-0 51	50	12.6	9.6	3.2	
DF40B-60DS-0.4V(51)	684-4049-4 51	60	14.6	11.6		
DF40B-80DS-0.4V(51)	684-4052-9 51	80	18.6	15.6		
DF40C-20DS-0.4V(51)	684-4005-9 51	20	6.6	3.6	1.0	
DF40C-24DS-0.4V(51)	684-4006-1 51	24	7.4	4.4	1.2	
DF40C-30DS-0.4V(51)	684-4007-4 51	30	8.6	5.6	1.5	
DF40C-34DS-0.4V(51)	684-4023-0 51	34	9.4	6.4	2.3	
DF40C-40DS-0.4V(51)	684-4008-7 51	40	10.6	7.6	3.2	
DF40C-50DS-0.4V(51)	684-4009-0 51	50	12.6	9.6		
DF40C-60DS-0.4V(51)	684-4004-6 51	60	14.6	11.6		
DF40C-70DS-0.4V(51)	684-4016-5 51	70	16.6	13.6		
DF40C-80DS-0.4V(51)	684-4002-0 51	80	18.6	15.6		
DF40C-90DS-0.4V(51)	684-4124-8 51	90	20.6	17.6		
DF40C-100DS-0.4V(51)	684-4033-4 51	100	22.6	19.6		



## 4.2.2. 3mm Stacking

### Height

#### 4.2.2. 3mm Stacking Height

Stacking Height 3mm;

Part Number: DF40HC(3.0)-30DS-0.4V(51) and DF40HC(3.0)-100DS-0.4V(51)

Stacking Height 3mm;

Part Number: DF40HC(3.0)-30DS-0.4V(51) and DF40HC(3.0)-100DS-0.4V(51)

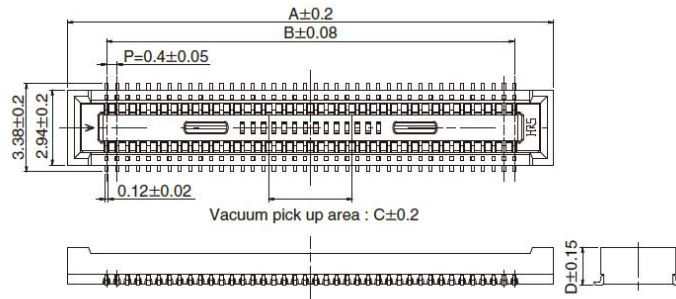
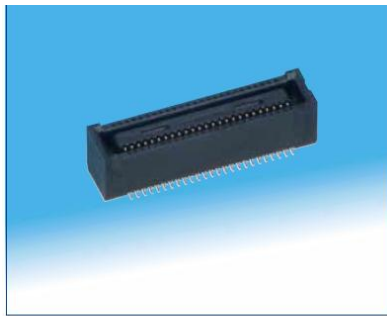

#### ◆ Recommended PCB layout

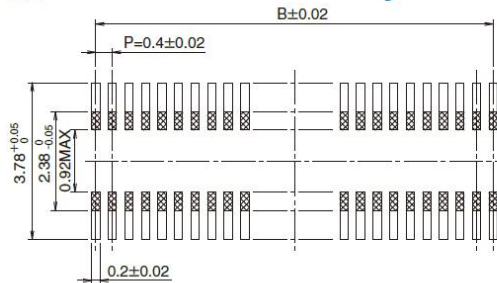

DF40HC(Without reinforcing metal fitting)

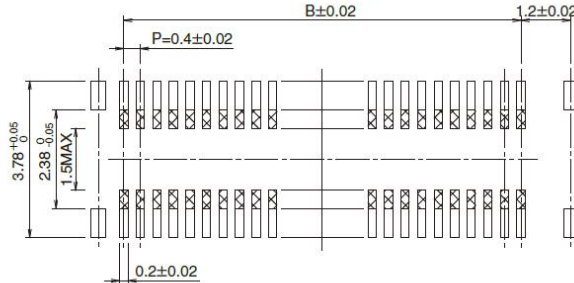

DF40HB(With reinforcing metal fitting)

Unit : mm

Part No.	HRS No.	No. of Contacts	A	B	C	D
DF40HC(3.0)-30DS-0.4V(51)	684-4098-0 51	30	8.6	5.6	1.5	2.9
DF40HC(3.0)-40DS-0.4V(51)	684-4169-6 51	40	10.6	7.6	3.2	
DF40HC(3.0)-44DS-0.4V(51)	684-4076-7 51	44	11.4	8.4		
DF40HC(3.0)-50DS-0.4V(51)	684-4099-2 51	50	12.6	9.6		
DF40HC(3.0)-60DS-0.4V(51)	684-4100-0 51	60	14.6	11.6		
DF40HC(3.0)-70DS-0.4V(51)	684-4138-2 51	70	16.6	13.6		
DF40HC(3.0)-80DS-0.4V(51)	684-4180-9 51	80	18.6	15.6		
DF40HC(3.0)-90DS-0.4V(51)	684-4161-4 51	90	20.6	17.6		
DF40HC(3.0)-100DS-0.4V(51)	684-4151-0 51	100	22.6	19.6		

# Chapter 5. Power and Reset

## 5.1 Power Source

SOM only requires +5V power input (at +5V\_IN of CN1). It then generates local voltage rails for all components through on-board PMIC.

- Power supply voltage : 5V +/- 0.3V
- Power supply current: 2A

## 5.2 Power Control and Monitoring

Power control and monitoring on SoM is implemented by using the NXP Power Management Integrated Circuit (PMIC) PCA9450CHN, designed specifically for the NXP i.MX8M Plus family of application processors.

PCA9450CHN provides Dynamic Voltage Scaling via I<sup>2</sup>C bus and/or digital input PMIC\_STBY\_REQ, and is accessible via I2C1 bus of i.MX8M Plus, I2C access address as following:

I2C Slave Address		
7-bit Slave Address	8-bit Write Address	8-bit Read Address
0x25, 0b 010 0101	0x4A, 0b 0100 1010	0x4B, 0b 0100 1011

## 5.3 Power Rail In/Out

There are three power output and a power input for GPIO reference voltage via CN1 BTB connector.

**Caution:**

- VSD\_3V3 is just for Micro SD card circuit, do not connect to any other circuit.
- VDD\_3V3 can only provide 600mA current for other circuit on base board, don't connect high current beyond 600mA device or you might brownout the system.
- VDD\_1V8 can only provide 600mA current for other circuit on base board, don't connect high current beyond 600mA device or you might brownout the system
- GPIO\_VREF is reference power input just for some GPIOs in GPIO\_VREF power domain, it must be connected to a power supply, suggest to connect GPIO\_VREF to

<a href="http://www.emtop-tech.com">www.emtop-tech.com</a>	<a href="https://github.com/EMTOP-TECH/SOM-IMX8MP">https://github.com/EMTOP-TECH/SOM-IMX8MP</a>
<a href="mailto:sales@emtop-tech.com">sales@emtop-tech.com</a>	<a href="mailto:support@emtop-tech.com">support@emtop-tech.com</a>

VDD\_3V3 or VDD\_1.8V on base board for different application.

<a href="http://www.emtop-tech.com">www.emtop-tech.com</a>	<a href="https://github.com/EMTOP-TECH/SOM-IMX8MP">https://github.com/EMTOP-TECH/SOM-IMX8MP</a>
<a href="mailto:sales@emtop-tech.com">sales@emtop-tech.com</a>	<a href="mailto:support@emtop-tech.com">support@emtop-tech.com</a>

## 5.4 External Reset Input

To ensure SoM work properly, suggest to connect a reset button to Pin 92 of CN1 to pull this pin to ground to reset SoM, a 10K pull-up resistor to 3.3V power supply has been installed on SOM board. Example circuit as following:

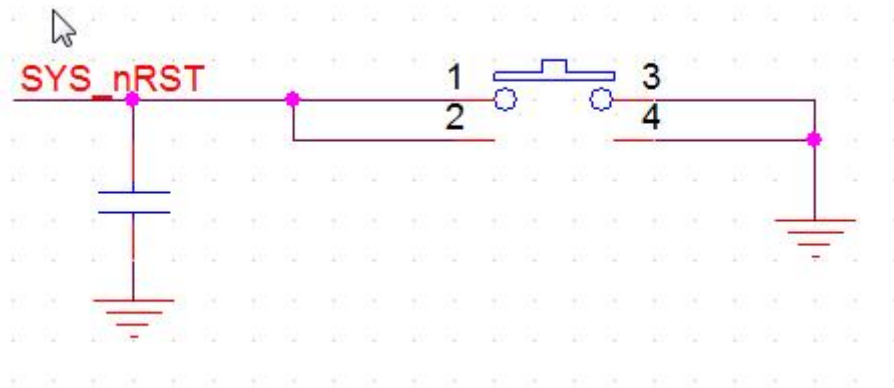

## 5.5 POR Reset Output

The POR reset output signal nEXTRST connects to Pin 100 of CN1, it can be used to reset other devices on base board. When PMIC is in powering up, nEXTRST keeps Low, after the power-up finished, nEXTRST will change to High, then the system starts to run.

A 10K pull-up resistor to 3.3V power supply has been installed on SOM board.

## 5.6 On-Off

ONOFF signal on Pin 99 of CN1 is used to turn on and off SoM, or to wake up SoM from an lower power mode.

A 100K pull-up resistor to 1.8V power supply has been installed on SOM board. Example circuit as following:

<a href="http://www.emtop-tech.com">www.emtop-tech.com</a>	<a href="https://github.com/EMTOP-TECH/SOM-IMX8MP">https://github.com/EMTOP-TECH/SOM-IMX8MP</a>
<a href="mailto:sales@emtop-tech.com">sales@emtop-tech.com</a>	<a href="mailto:support@emtop-tech.com">support@emtop-tech.com</a>

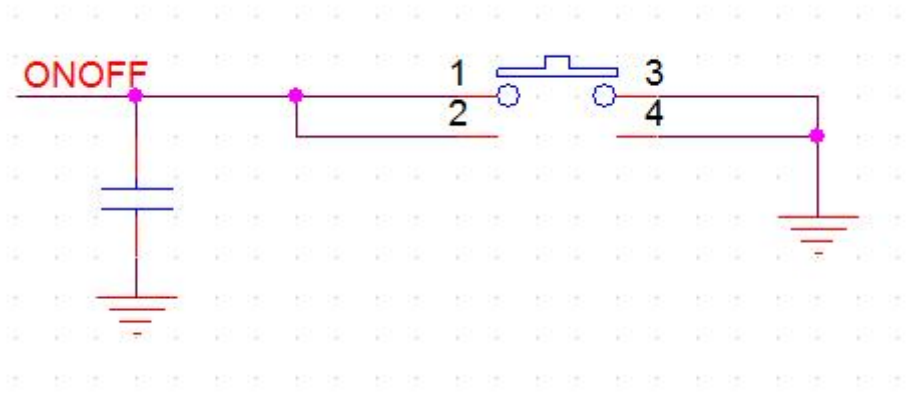

<a href="http://www.emtop-tech.com">www.emtop-tech.com</a>	<a href="https://github.com/EMTOP-TECH/SOM-IMX8MP">https://github.com/EMTOP-TECH/SOM-IMX8MP</a>
<a href="mailto:sales@emtop-tech.com">sales@emtop-tech.com</a>	<a href="mailto:support@emtop-tech.com">support@emtop-tech.com</a>

# Chapter 6. Base board design guide

## 6.1. Trace impedance requirement

The following table lists the recommended impedance for high-speed signals on the baseboard.

Signal group	Impedance	PCB manufacture tolerance
All single-ended signal, unless specified	50 Ohm single-ended	+/-10%
PCIe colck and TX/RX data pair	85 Ohm differential	+/-10%
USB differential signals	90 Ohm differential	+/-10%
Ethernet Differential signals	100 Ohm differential	+/-10%
MIPI DSI	100 Ohm differential	+/-10%
MIPI CSI	100 Ohm differential	+/-10%
LVDS	100 Ohm differential	+/-10%

## 6.2. High-speed signal trace length compensation

The following table lists the trace length of high-speed signals, including MIPI CSI, MIPI DSI, PCIe, USB and Giga Ethernet. These signals are high-speed signals that require the total etched trace lengths to be equal to each other. You must incorporate the length difference on your baseboard to ensure that the trace length for all high-speed signals match each other.

Name	Etch length (mil)	Name	Etch length (mil)
<b>MIPI CSIO</b>			
CAM0_D0_P	459.12	CAM0_D0_N	461.26
CAM0_D1_P	471.4	CAM0_D1_N	473.96
CAM0_D2_P	1031.44	CAM0_D2_N	1026.86
CAM0_D3_P	1174.98	CAM0_D3_N	1179.38
CAM0_C_P	484.13	CAM0_C_N	488.4
<b>MIPI CSI1</b>			
CAM1_D0_P	532.73	CAM1_D0_N	535.88
CAM1_D1_P	447.05	CAM1_D1_N	448.68
CAM1_D2_P	294.95	CAM1_D3_N	292.39
CAM1_D3_P	368.24	CAM1_D3_N	363.46
CAM1_C_P	373.52	CAM1_C_N	378.45
<b>MIPI DSI</b>			
DSI_D0_P	824.5	DSI_D0_N	819.82
<a href="http://www.emtop-tech.com">www.emtop-tech.com</a>		<a href="https://github.com/EMTOP-TECH/SOM-IMX8MP">https://github.com/EMTOP-TECH/SOM-IMX8MP</a>	
<a href="mailto:sales@emtop-tech.com">sales@emtop-tech.com</a>		<a href="mailto:support@emtop-tech.com">support@emtop-tech.com</a>	

DSI_D1_P	831.79	DSI_D1_N	836.69
DSI_D2_P	1006.49	DSI_D2_N	1006.2
DSI_D3_P	813.07	DSI_D3_N	809.38
DSI_C_P	1178.92	DSI_C_N	1181.28
<b>HDMI</b>			
HDMI_TX0_P	1389.48	HDMI_TX0_N	1384.99
HDMI_TX1_P	1380.25	HDMI_TX1_N	1379.55
HDMI_TX2_P	1388.12	HDMI_TX2_N	1387.14
HDMI_CLK_P	1393.14	HDMI_CLK_N	1393.25
<b>LVDS</b>			
LVDS0_TX0_P	382.16	LVDS0_TX0_N	384.21
LVDS0_TX1_P	436.25	LVDS0_TX1_N	439.42
LVDS0_TX2_P	511.26	LVDS0_TX2_N	515.85
LVDS0_TX3_P	657.15	LVDS0_TX3_N	660.78
LVDS0_CLK_P	595.14	LVDS0_CLK_N	599.58
<b>PCIe</b>			
PCIe_CLK_P	663.57	PCIe_CLK_N	667.63
PCIe_RX_P	449.1	PCIe_RX_N	452.99
PCIe_TX_P	438.67	PCIe_TX_N	434.86
<b>USB1</b>			
USB1_P	333.95	USB1_N	337.34
USB1_TXP	762.29	USB1_TXN	759.5
USB1_RXP	798.09	USB1_RXN	797.6
<b>USB2</b>			
USB2_P	788.68	USB2_N	768.16
USB2_TXP	737.63	USB2_TXN	741.51
USB2_RXP	615.81	USB2_RXN	620.24
<b>Ethernet</b>			
Ethernet_Pair0_P	400.17	Ethernet_Pair0_N	404.79
Ethernet_Pair1_P	463.43	Ethernet_Pair1_N	461.46
Ethernet_Pair2_P	517.69	Ethernet_Pair2_N	521.3
Ethernet_Pair3_P	611.1	Ethernet_Pair3_N	606.7

<a href="http://www.emtop-tech.com">www.emtop-tech.com</a>	<a href="https://github.com/EMTOP-TECH/SOM-IMX8MP">https://github.com/EMTOP-TECH/SOM-IMX8MP</a>
<a href="mailto:sales@emtop-tech.com">sales@emtop-tech.com</a>	<a href="mailto:support@emtop-tech.com">support@emtop-tech.com</a>

## 6.3. Boot Mode

Using the BOOT\_MODE[1:0] pins to configure SoM boot mode setting as indicated in the following tables. The default configuration is [10] booting form eMMC.

BOOT_MODE1	BOOT_MODE0	Boot Modes
1	0	USDHC3 (eMMC boot only, SD3 8-bit)
0	1	USB Serial Download

If the designer desires to boot the board up from any other storage device, please refer the following table to change the boot-up configuration, further information please refer to i.MX 8M Mini Applications Processor Reference Manual.

Caution: The pull-up resistor of boot configuration should be connected to VDD\_3V3 from J3.

On-board eMMC: Connected to uSDHC3 8 bit

TF single on BTB connector: Connected to uSDHC2

On-board QSPI Flash: Connected to QSPI, 1.8V 64M bit QSPI flash, W25Q64FW

## 6.4. System Status LED

There is a Green LED on SoM for system status indicator, circuit as following:

The LED is controlled by GPIO of Pin T28 (GPIO3.IO16) of CPU.



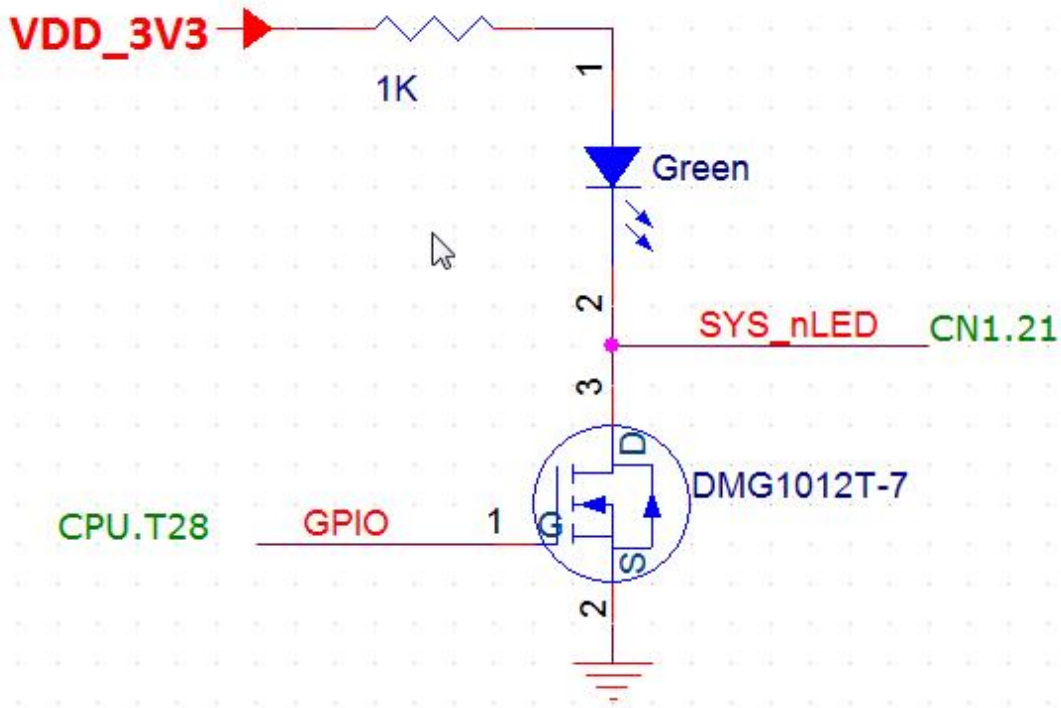

## 6.5. Giga Ethernet

GIGA Ethernet circuit as following:

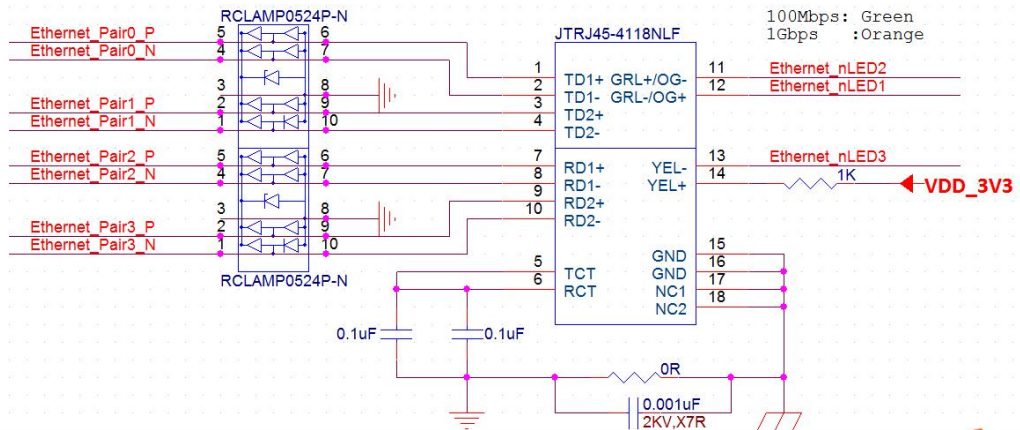

The ESD RCLAMP0524P-N is optional.

For the LED status, Yellow LED indicates link active;

Green LED indicates 100M status;

Orange LED indicates 1000M status;

<a href="http://www.emtop-tech.com">www.emtop-tech.com</a>	<a href="https://github.com/EMTOP-TECH/SOM-IMX8MP">https://github.com/EMTOP-TECH/SOM-IMX8MP</a>
<a href="mailto:sales@emtop-tech.com">sales@emtop-tech.com</a>	<a href="mailto:support@emtop-tech.com">support@emtop-tech.com</a>

Symbol	10M Link	10M Active	100M Link	100M Active	1000M Link	1000M Active
LED_10_100	OFF	OFF	ON	ON	OFF	OFF
LED_1000	OFF	OFF	OFF	OFF	ON	ON
LED_ACT	ON	BLINK	ON	BLINK	ON	BLINK

**NOTE:** Notes: on = active; off = inactive

## 6.6. Micro SD Card

It is strongly recommended that use the power source VSD\_3V3 output from Pin 75 of CN1 to power the Micro SD Card, and VSD\_3V3 DO NOT use to power other devices. The voltage level of VSD\_3V3 will change from 3.3V to 1.8V when high speed card inserted. Note that ESD circuit is needed for reliable application.

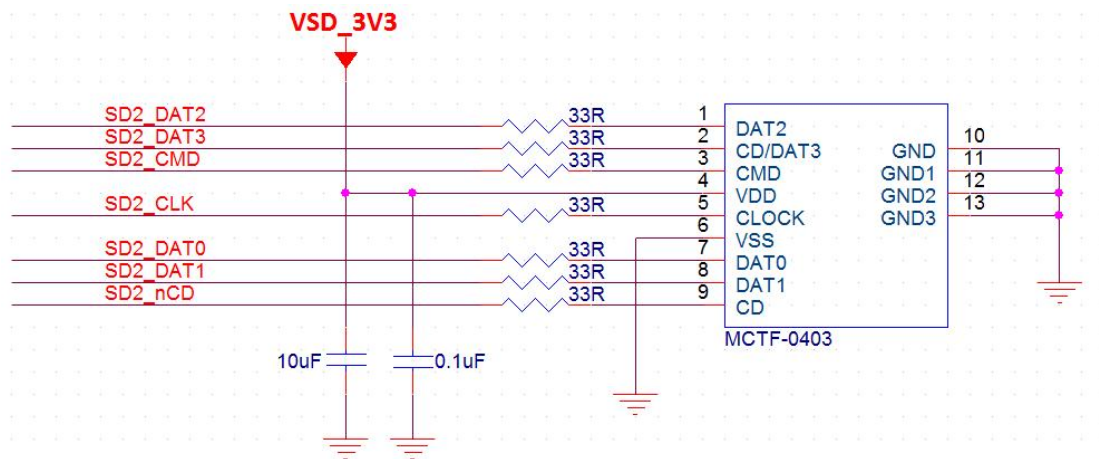

## 6.7. HDMI

HDMI circuit as following:

Note that ESD is not needed because the ESD circuit has been integrated on SoM

<a href="http://www.emtop-tech.com">www.emtop-tech.com</a>	<a href="https://github.com/EMTOP-TECH/SOM-IMX8MP">https://github.com/EMTOP-TECH/SOM-IMX8MP</a>
<a href="mailto:sales@emtop-tech.com">sales@emtop-tech.com</a>	<a href="mailto:support@emtop-tech.com">support@emtop-tech.com</a>

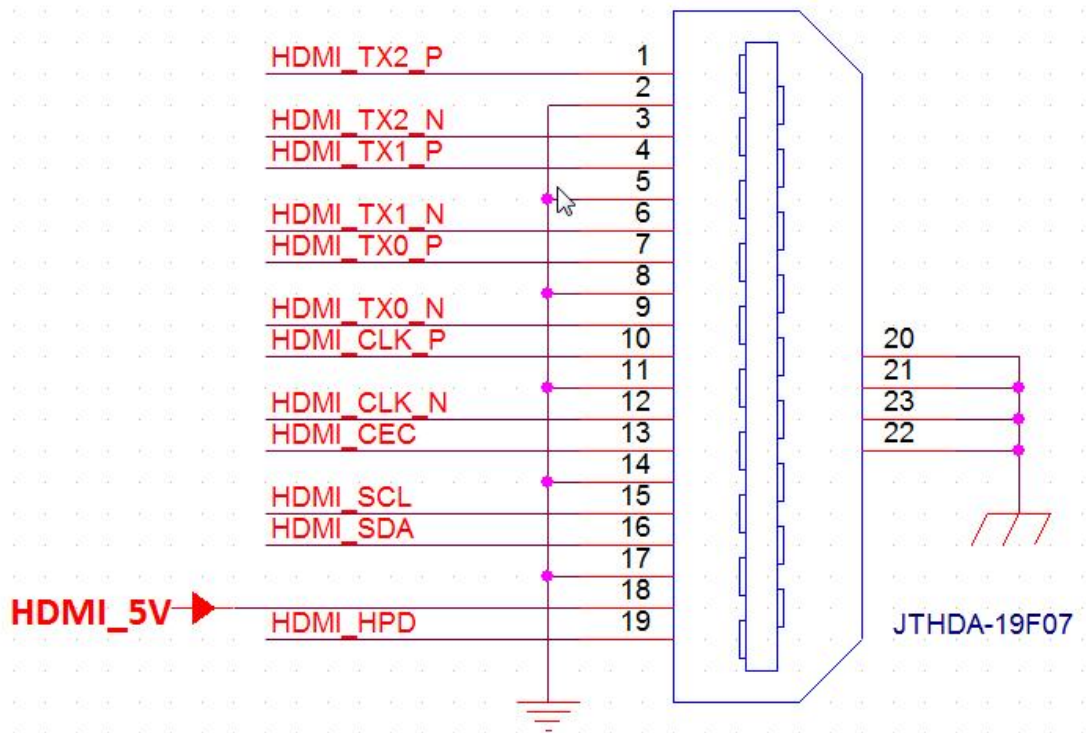

## 6.8. Mini PCIe

The following circuit demonstrates how to connect to mini PCIe connector via PCIe and USB bus.

You can easily extend 4G application via mini PCIe 4G module.

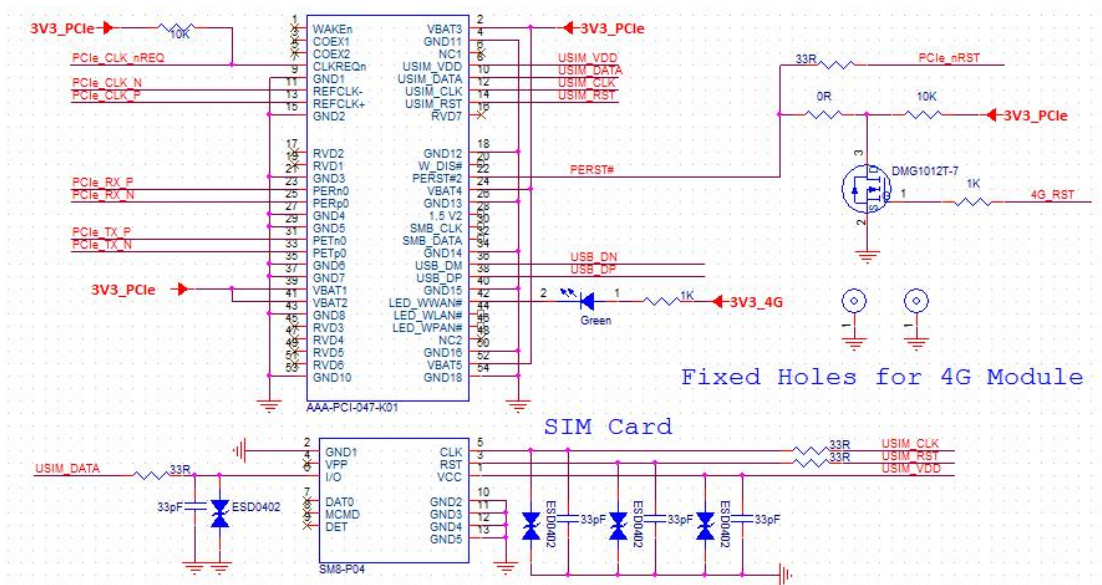

Note that 0.1uF AC coupling capacitor has been integrated on SoM board for these signals:

<a href="http://www.emtop-tech.com">www.emtop-tech.com</a>	<a href="https://github.com/EMTOP-TECH/SOM-IMX8MP">https://github.com/EMTOP-TECH/SOM-IMX8MP</a>
<a href="mailto:sales@emtop-tech.com">sales@emtop-tech.com</a>	<a href="mailto:support@emtop-tech.com">support@emtop-tech.com</a>

PCle\_CLK\_P

PCle\_CLK\_N

PCle\_TX\_P

PCle\_TX\_N

External 0.1uF AC coupling capacitor is needed on base board when directly connecting PCIe device for these signals:

PCle\_RX\_P

PCle\_RX\_N